

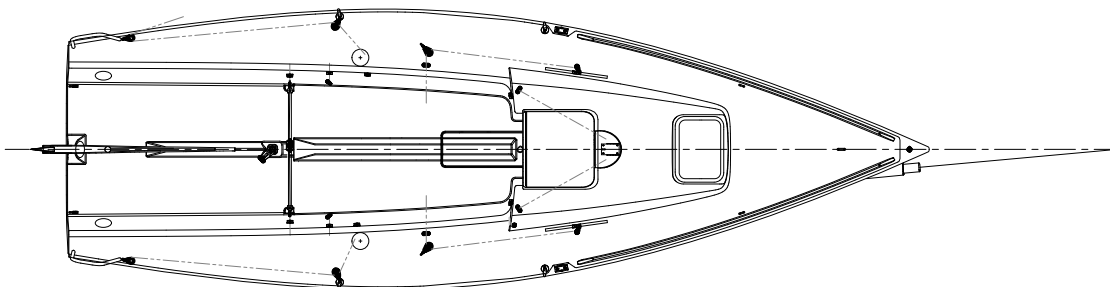

Yacht Name:.....

Owner Name:.....



## Table of Contents

|  |                                   |
|--|-----------------------------------|
| <b>Introduction</b> .....                          | 4                                 |
| <b>CE Certification</b> .....                      | 5                                 |
| <b>Specifications</b> .....                        | 7                                 |
| <b>Important Contacts</b> .....                    | 8                                 |
| <b>Getting to Know your J/70</b> .....             | 9                                 |
| Hull, Deck & Structure.....                        | 9                                 |
| Lifting Keel & Kelp Cutter.....                    | 9                                 |
| Rudder, Tiller & Steering Hardware.....            | 11                                |
| Bow Sprit System & Components.....                 | 11                                |
| Companionway Hardware.....                         | 11                                |
| Mast Boom & Standing Rigging.....                  | 12                                |
| Jib Halyard System.....                            | 13                                |
| Jib Furling System.....                            | 13                                |
| Cockpit Safety Lines.....                          | 13                                |
| Running Rigging.....                               | 14                                |
| <b>Rigging Your J/70</b> .....                     | 15                                |
| Mainsheet & Traveler.....                          | 17                                |
| Backstay System.....                               | 18                                |
| Boom Vang & Cunningham.....                        | 19                                |
| Halyard & Mast Base Layout.....                    | 20                                |
| Headstay Layout.....                               | 21                                |
| 2:1 Jib Sheet Layout & Boom Layout.....            | 22                                |
| Deck Hardware Layout.....                          | 23                                |
| Bow Sprit & Furler Controls.....                   | 24                                |
| Bow Drainage Locker & Access.....                  | 25                                |
| Custom Keel Crane.....                             | 26                                |
| <b>Launching &amp; Hauling your J/70</b> .....     | 27                                |
| <b>Tuning the Rig</b> .....                        | 29                                |
| <b>Sail Handling Tips</b> .....                    | 29                                |
| <br>   |                                   |
| APPENDIX A - Best Practices - Boat Inspection..... | 31                                |
| APPENDIX B – Marlow Running Rigging.....           | 36                                |
| <br>   |                                   |
| <b>CCFC Limited Warranty</b> .....                 | Included at the end of this Guide |

## Introduction

WELCOME ABOARD and welcome to the J/Boats family of owners. Your boat is designed and engineered to be the strongest, best performing, easiest-to-use, and most comfortable sailing boat of its type.

Sailing involves risk, most of which can be minimized with advance planning and proper seamanship. As a new J/70 owner, you should become proficient in all aspects of handling the vessel under sail and power, and be well versed with emergency procedures before undertaking any extended passage. The owner is further responsible for any required state registration or federal documentation, accident reporting, outfitting the vessel with proper safety equipment, and the safe operation of the vessel. Your J/Boats Dealer will be happy to refer you to Boating Safety Courses or other seminars available.

Please be sure to complete the enclosed warranty form and mail to C&C Fiberglass Components, Inc. (CCFC)

This owner manual is furnished for the owner's benefit, and shall in no way be construed as any sort of warranty or contract, express or implied, creating any obligation on the part of J/Boats, Inc., with respect to any fact or facts or any advice or opinions contained herein. The sole and exclusive warranty of the product is the CCFC Warranty described in the appendix hereto and furnished with the yacht.

J/BOATS, INC. HEREBY DISCLAIMS ANY AND ALL WARRANTIES, EXPRESS OR IMPLIED, INCLUDING ANY WARRANTY OF FITNESS FOR A PARTICULAR PURPOSE OR ANY IMPLIED WARRANTY OF MERCHANTABILITY.

## CE Certification:

With standard equipment, the J/70 Meets Category C Requirements for CE Certification. J/70s built by CCFC for European clients carry the Category C Certificate. The J/70 is intended for daytime navigation only, (not during night).

### CE Certification Notice:

This manual has been compiled to help you to operate your J/70 with safety and pleasure. It contains details of the J/70; the equipment supplied or fitted, its systems and information on its operation. Please read it carefully, and familiarize yourself with the craft before using it.

Even when your boat is categorized for them, the sea and wind conditions corresponding to the design categories A, B, and C range from strong gale to severe conditions, open to the hazards of a freak wave or gust, and are therefore dangerous conditions, where only a competent, fit and trained crew using a well maintained boat can satisfactorily operate.

Ensure that the anticipated wind and sea conditions will correspond to the design category of your boat, and that you and your crew are able to handle the boat in these conditions.

This owner's manual is not a course on boating safety or seamanship. If this is your first boat, or you are changing to a type of boat you are not familiar with, for your own comfort and safety, please ensure that you obtain handling and operating experience before "assuming command" of the boat. Your dealer or national sailing federation or yacht club will be pleased to advise you of local sea schools, or competent instructors.

This owner's manual is not a detailed maintenance or trouble shooting guide. In case of difficulty, refer to the boat dealer, builder or its representative. Always use trained and competent people for maintenance, fixing or modifications. Modifications that may affect the safety characteristics of the craft shall be assessed, executed and documented by competent people. The boat builder cannot be held responsible for modifications he has not approved.

NOTE: Any change in the disposition of the masses aboard may significantly affect the stability, trim and performance of your boat. Users of this boat are advised that:

- All crew should receive suitable training;
- The boat should not carry more than the manufacturer's recommended load;
- Bilge water should be kept to a minimum;
- Stability is reduced by any weight added high up;
- In rough weather, hatches, lockers and doorways should be closed to minimize the risk of flooding;
- Stability may be reduced when towing or lifting heavy weights using a davit or boom;
- Breaking waves are serious stability hazard.

In some countries a driving license or authorization are required, or specific regulations are in force. Always maintain your boat properly and make allowance for the deterioration that will occur in time and as a result of heavy use or misuse of the boat.

Any boat – no matter how strong it may be, can be severely damaged if not used properly. This is not compatible with safe boating. Always adjust the speed and direction of the craft to sea conditions. If your boat is fitted with a life raft, read carefully its operating manual. The crew should be familiar with the use of all safety equipment (harness, flares, life raft, etc.) and emergency maneuvering (man overboard recovery, towing, etc.); sailing schools and clubs regularly organize drill sessions.

**PLEASE KEEP THIS MANUAL IN A SECURE PLACE, AND HAND IT OVER TO THE NEW OWNER WHEN YOU SELL THE CRAFT.**

## Definitions of CE design categories:

**A OCEAN:** Designed for extended voyages where conditions may exceed wind force 8 (Beaufort scale) and significant wave heights of 4 m and above but excluding abnormal conditions, and vessels largely self-sufficient.

**B OFFSHORE:** Designed for offshore voyages where conditions up to, and including wind force 8 and significant wave heights up to, and including, 4 m may be experienced.

**C INSHORE:** Designed for voyages in coastal waters, large bays, estuaries, lakes and rivers where conditions up to, and including, wind force 6 and significant wave heights up to, and including, 2 m may be experienced.

**D SHELTERED WATERS:** Designed for voyages on sheltered coastal waters, small bays, small lakes, rivers and canals when conditions up to, and including, wind force 4 and significant wave heights up to, and including, 0,3 m may be experienced, with occasional waves of 0,5 m maximum height, for example from passing vessels.

**NOTE:** The significant wave height is the mean height of the highest one third of the waves, which approximately corresponds to the wave height estimated by an experienced observer. Some waves will be double this height.

## J/70 Recommended Loading

Maximum Crew = 6 People at 75 kg (165 lbs.) each.

Manufacturer's Recommended Maximum Total Load = 530 kg (1,168 lbs.) - Includes crew

This assessment has been made assuming that all standard equipment is aboard and that the boat in light craft condition has a mass of 794 kg (1750 lbs.). This recommended maximum load takes into account the mass of the following:

- a) The number of persons onboard: Where children are carried as part of the crew the maximum number of persons may be exceeded provided that each child's mass does not surpass a limit of 37.5 kg (83 lbs.) and the total persons mass (75 kg) is not exceeded.
- b) basic equipment mass of  $(LH-2.5)^2$  considered not to be less than 10kg.
- c) stores and cargo (if any), dry provisions, consumable liquids [not covered by d) or e)], and miscellaneous equipment not included in the light craft mass or in b);
- d) consumable liquids (fresh water, fuel) in portable tanks filled to the maximum capacity;
- e) consumable liquids (fresh water, fuel) in permanently installed tanks filled to the maximum capacity;
- f) a life raft or dinghy when intended to be carried.

This boat has been assessed using the Stability Index (STIX), which is a measure of the overall stability safety and considers the effects of boat length, displacement, hull proportions, stability characteristics and resistance to down flooding. This assessment has yielded the following data:

J/70 Mass in Minimum Operating Condition (mMOC): STIX = 22.53  
Angle of Vanishing Stability = 122 degrees

J/70 Mass in Loaded Displacement Condition (mLDC): STIX = 18.20  
Angle of Vanishing Stability = 107 degrees

## Specifications

| MODEL                                  | J/70   |
|--|--|
| LOA (Lh)                               | 6.934m (22.75')                                      |
| LWL (Lwl)                              | 6.240m (20.47')                                      |
| Beam (Bh)                              | 2.249m (7.38')                                       |
| Draft : [Max Loaded Draft] - Keel Down | 1.45m (4.75') : [1.50m (4.92')]                      |
| Rudder Draft                           | .914m (3.00')  |
| Ballast                                | 286 kg (630 lbs.)                                    |
| Ballast Type                           | Cast lead w/3% antimony                              |
| Displacement - standard boat           | 794 kg (1,750 lbs.)                                  |
| 100% Sail Area (triangles)             | 21.0 sq m (226 sq ft)                                |
| Jib Area (OD Class)                    | 10.31 sq m (111 sq ft)                               |
| Mainsail Area (OD Class)               | 16.07 sq m (173 sq ft)                               |
| Spinnaker Area (OD Class)              | 45.61 sq m (491 sq ft)                               |
| I                                      | 8.159m (26.77')                                      |
| ISP                                    | 9.189m (30.15')                                      |
| J                                      | 2.341m (7.68')                                       |
| P                                      | 7.973m (26.16')                                      |
| E                                      | 2.877m (9.44')                                       |
| Headstay Pin to Pin Length (05-14-12)  | 8432 mm (27' 8" turnbuckle half open)                |
| Maximum Recommended Outboard Engine    | 4hp  |
| Limit of Positive Stability (mMOC)     | 122 degrees  |
| Hull & Deck Core Material              | Hull - Baltek® AL600 Balsa, Deck - Corecell Foam     |
| Hull & Deck Molding Process            | Hand Lay-up  |
| Mast Height Above Water                | 10.00 m (32' 10") not including masthead instruments |
| Mast Length                            | 9.067m (29.75')                                      |
| DSPL/Length                            | 91   |
| Upwind SA/DSPL (OD Class)              | 31   |
| Downwind SA/DSPL (OD Class)            | 73   |
| CE Certification Design Category       | Category C   |

## Important Contacts

|                   |           |
|-------------------|-----------|
| Dealer:           | Phone:    |
| Street:           | Web Site: |
| City, State, Zip: | E mail:   |

### Design & Marketing:

**J/Boats, Inc.**  
 PO Box 90  
 Newport, RI 02840  
[info@jboats.com](mailto:info@jboats.com)  
[www.jboats.com](http://www.jboats.com)  
 401-846-8410

### Manufacturer:

**C&C Fiberglass Components, Inc.**  
 75 Ballou Blvd.  
 Bristol, RI 02809  
[info@ccfc.com](mailto:info@ccfc.com)  
[www.ccfc.com](http://www.ccfc.com)  
 401-254-4342

### J/70 Suppliers

Global BSI Inc. (foredeck hatch)  
 Southern Spars - Rig Pro USA  
 Harken East  
 Ronstan USA

### Phone

45-7322-2222  
 401-253-4858  
 401-849-8278  
 401-293-0539

### Web

[www.bsdk.com](http://www.bsdk.com)  
<http://rigpronewport.wordpress.com/>  
[www.harken.com](http://www.harken.com)  
[www.ronstan.us](http://www.ronstan.us)



## Getting to Know Your J/70

### Hull, Deck & Structure

The engineering and construction of the J/70 Hull, Deck, Rudder, Keel and Structure meet the requirements of ISO Standard 12215 1-5 titled Hull Construction & Scantlings for Category C. These are International minimum standards required for all new boats.

**Hull:** The J/70 hull is built with E-glass and balsa core sandwich construction with white gelcoat finish and VE resin in the outer layer for osmotic blister protection. Bi-axial and unidirectional glass fabrics are used on both sides of the balsa core and are combined with local reinforcements in key highly loaded areas including the hull centerline, keel trunk, transom, bow stem, bow sprit housing and hull flanges. The hull is designed with an inward turning hull flange trimmed to match the finished deck edge allowing for a significant overlap at the glued hull/deck joint. Interior hull surfaces in the cabin areas are finished with a brushed on "air-dry" gelcoat finish.

**Deck:** Deck construction is E-glass and Core-cell foam sandwich construction with white gelcoat finish. Hi density Airex Pxc core blocking is used in place of Core-cell in areas of deck hardware penetrations. Additional E-glass reinforcements are specified for areas of deck hardware, mast step, rudder hardware, jib furler, keel recess, toerails, as well as edges and corners as necessary. The deck is bonded to the hull flange with Plexus MA 550, a proven, strong, watertight and lightweight method approved by ABS. Interior deck surfaces in the cabin areas are finished with a brushed on "air-dry" gelcoat finish.

**Interior Structure:** J/70 interior structure includes several transverse bulkheads, a V-berth platform, reinforced keel trunk and longitudinal hull support members. Each of these is built with e-glass, gelcoat and in some cases foam core. The layout and construction are specifically engineered to best distribute the sailing loads of the boat per ISO. All fiberglass internal members are glue bonded and/or tabbed with glass tape directly to hull and deck surfaces. The mast compression post is anodized aluminum and engineered to transfer mast compression loads to the hull. This post is fastened mechanically through the deck and at the fiberglass base support. Two plastic access inspection ports are installed at the aft bulkhead and on top of the aft end of the V-berth. It is advisable to inspect these areas periodically for moisture or condensation build up and dry out prior to extended storage.

### J70 Lifting Keel

The J/70 is equipped with a lifting keel that enables owners to easily ramp launch and store their boat on a trailer without the need to rely on boat yards or yacht clubs. The keel system and the boat are designed with stability to operate in open water and under sail ONLY with the keel in its fully lowered position with keel safety plate properly secured in place.

### Keel Construction

J/70 keel weighs 630 lbs. (285k) and is built with a complete molded fiberglass shell surrounding internal structure/ballast composed of a fabricated 316SS spar and lifting bolt cast into a lead bulb. Internals also include structure to support the leading edge and kelp cutter installation. Four wedges are through-bolted at the head of the keel assembly to support and position the keel within the boat. Top of the keel is finished with a keel lifting eye positioned inline with the keel CG.

**CAUTION: USE OF A YACHT CLUB SINGLE-POINT HOIST OR OTHER NON-STANDARD CRANE TO RAISE THE J/70 KEEL MAY CAUSE DAMAGE TO BOTH THE KEEL AND THE HULL AT THE KEEL TRUNK.**

*J/70 keel lifting eye should only be used with the standard aluminum J/70 keel crane that is designed with a stop to prevent over-hoisting the keel bulb and kelp cutter into the bottom of the hull. Do not attempt to combine the boat lift padeyes with the keel lifting eye during hoist operations.*

### Keel Safety Plate

J/70 keel system includes a substantial 316 SS plate that bridges the top of the keel to prevent it from sliding out of the keel trunk should the boat ever become inverted or beyond a 90 degree horizontal position. The SS plate is secured to the boat with two bronze nut fasteners on the SS studs mounted on each side of the keel recess. It is important to install this system properly each time the keel is lowered into position for sailing and good practice to inspect the system each time the boat is used.

### Kelp Cutter

The J/70 keel is equipped with a stainless rod/kelp cutter that travels vertically within a slotted tube at the leading edge of the keel. Kelp or seaweed is "cut" by pulling up on the kelp cutter knob (at front end of cockpit) until the cutting blade hits the G-10 composite cutting block that's molded into the hull. Once the cutter has been used several times, a narrow groove will develop in the G-10 block which will actually improve its cutting action.

While sailing, the knob and blade are stored in the down position which means (on an L-shaped keel) that the profile of the cutting blade projects forward of the leading edge of the keel, several feet below the waterline. There is a blunt radius on the front of the blade, with only the top horizontal surface sharp. You'll find that most weed that catches keels and rudders is floating, so remains near the top of the foil.

**CAUTION – THE KELP CUTTER BLADE IS SHARP AND CAN CAUSE INJURY. WHEN NOT SAILING, PULL THE KELP CUTTER KNOB UP TO ITS MOST VERTICAL POSITION (and lash to the boom), SO THAT THE BLADE IS AGAINST THE HULL AND DOES NOT POSE ANY RISK OF INJURY WHILE WASHING THE KEEL OR SWIMMING NEAR THE BOAT.**

### Keel Crane System

J/70 keel crane is a custom fabricated aluminum crane with an integral 30:1 worm gear winch and Harken 2:1 tackle with floating Harken wire block and twist shackle. The keel crane line is a length of 12 strand 6mm HMPE (Dyneema) with an average breaking load of over 7,600 lbs. (J/70 keel weighs 630 lbs.). The keel crane fits into a socket behind the keel recess under the keel cover hatch. It is a simple matter to shackle the Harken block to the keel lifting eye to prepare to lift the keel. Keel crane winch is

equipped with a removable handle and a  $\frac{3}{4}$ " lock nut for use with a portable drill and  $\frac{3}{4}$ " extended length socket. The keel can be manually winched up or down in approx. 2-3 minutes and/or with a power drill in approx. 20-30 seconds. Care should be taken at all times during keel lift operations that the system is operating smoothly. It is advisable to always begin lifting or lowering operations with the manual handle to insure the keel is moving freely. Also it is a good idea to use a lubricant on the head of the keel and wedges (McLube or similar) to insure smooth operations. Inspection of the keel lifting line and cleaning with fresh water should be performed on a regular basis to guard against wear or premature degradation of the lifting line. Any indications of unusual wear should be addressed by replacing the line.

## Storage

The keel crane system and line are designed for temporary launch and hauling operations and not intended for extended storage under load. Owners should seek other methods of long term support of the keel weight when the boat is on a boat lift, for instance, where the lifted keel may not be fully supported or on a cradle or trailer not specifically designed for the J/70. Care should also be taken in these instances regarding bracing the keel inside the keel trunk.

## Bracing a Lifted Keel

Because the keel, when in lifted position, can float within the keel trunk, owners should take great care to brace the keel trailing edge on each side with some soft material or carpeting inside the keel trunk prior to trailering or storing the boat for extended periods of time. We have found that mildly strapping the keel eye forward to the mast step eye on deck (when keel is in lifted position) can help brace the keel forward while on the trailer and then this combined with a strap around the trailing edge of the keel bulb to the trailer keel tie downs may be enough to keep the boat and keel braced together to the trailer. Please refer to the Triad Trailer owner manual for more specific information and trailering recommendations.

## Rudder, Tiller and Steering Hardware

J/70 rudder is molded with E-glass & VE resin with an epoxy foam core. The skins include triaxial glass fabric with several unidirectional supporting layers. There is additional reinforcement and/or blocking at all hardware penetrations as well as along the leading and trailing edges and the rudder head. The trailing edge is very narrow and as such is a damage prone area when handled poorly. Owners should use great care when removing and installing the rudder to avoid trailing edge damage.

The tiller is a molded gelcoat and E-glass curved tiller with an extendable tiller extension from Ronstan. This is attached to the top of the rudder with a single bolt and articulates vertically. Care should be taken not to stress the tiller by placing unnecessary weight on top of the forward end while sailing as this could lead to gelcoat cracks and other issues where it attaches to the rudder.

The rudder hardware includes two SS rudder straps bolted to the rudder, two SS transom mounted gudgeons and two SS rudder pins. The rudder pins are provided attached together with a lanyard and with retaining rings. Be sure to install the retaining rings below each gudgeon once the pins are installed. Water draft with the rudder installed is 3' so it is likely that the rudder will need to be installed after ramp launching and or before hauling up a ramp, depending on the height of the trailer support bunks

## Bow Sprit System & Components

J/70 bowsprit is a carbon tube with a special ferrule type end fitting at the outboard end for the spinnaker tack line. The sprit is provided with a simple hole for dead-ending the pole control line at its aft end and the sprit rides on two Delrin machined sprit bearings that are each bonded inside a fiberglass tube mounted in the bow of the boat to starboard. The center of this fiberglass tube is cut away (forward

of the forepeak bulkhead) and a bowsprit seal floats between the bearings to prevent water migration into cabin areas while sailing. An angled platform at the forward bulkhead pitches forward and down to the stem at the bow of the boat with an overboard drain on the starboard side. This allows any residual water that might collect from water pressure through the forward sprit bearing and/or rain or seawater through the Harken jib furling system to drain overboard. This compartment is accessible through a raised and sealed inspection cover from below decks. Bow sprit control line leads from the end of the bowsprit to a block mounted to the forward bulkhead then aft to the ferruled hole through the cabin face to starboard to the pole control cam cleat (see diagram).

## Companionway Hardware

J/70 is designed with a hinged and gasketed companionway cover that is fully removable by sliding to starboard once hinged to approximately 30 degrees. It is equipped with a SS eye and locking hasp mounted to the underside. There is also a companionway acrylic drop board provided with a sliding barrel bolt and hasp eye. Finally there is a shock cord and hook assembly attached to the boat on the starboard side in the vicinity of the companionway opening.

There are three positions designed for this system:

- 1) Closed and locked, drop board in place
- 2) Companionway covered: Cover installed, no drop board in place
- 3) Companionway Open: Cover and drop board stored below

For the closed and locked position the drop board must be in place and the barrel bolt on the front side locked into the side rail of the companionway to starboard. Then the companionway cover is installed and hasp is mated with the drop board hasp eye and boat can then be locked.

For the covered position the cover should be installed to its hinges and the shock cord attached to the SS eye mounted to the underside of the cover. This is designed to firmly hold the cover down while sailing. The shock cord may need tension adjustment from time to time.

The open position is a simple matter of removing both the cover and the drop board and storing these items securely below.

## Outboard Engine Bracket

The standard J/70 outboard bracket is an aluminum fabrication mounted to the transom on the starboard side with a UHMW block to accept typical small outboard motors. This bracket is engineered for a reasonable size outboard not to exceed 4hp or 50lbs (23k).

## Deck Hardware & Access Plates

The deck hardware of the J/70 includes a combination of bolt down and ship loose kits from Harken, Ronstan, BSI Hatch, Garhauer stainless and White Water Marine. All deck hardware is carefully located to provide for versatile operation of the boat and comfortable positioning of the crew. The deck mounted items are installed through reinforced areas of the deck using suitable deck sealants and fasteners. It is very important to plan carefully and take great care when mounting additional hardware\* or drilling any holes through the deck to both protect the watertight integrity of the deck and to not cause other unintended issues down the road. Please refer to photos and diagrams included in this manual to properly set up each piece of hardware. For the Harken tie-lite and loop blocks please refer directly to Harken instructions for set-up and recommended knots. Access plates are installed at the aft end of the cockpit to allow long-term management of deck hardware fasteners at the aft part of the boat.

\* Be sure to consult the J/70 Class Rules prior to mounting new hardware, as in most cases, changing the location of deck fittings is not permitted.

## Mast Boom & Standing Rigging

The J/70 mast & boom are built by Southern Spars of carbon fiber and painted black with white limit marks. The mast, masthead crane and spreaders are also built of carbon fiber and painted black.

The deck stepped mast has a SS tabernacle deck mounted plate with cast aluminum mast foot. The system allows the mast to articulate outboard in order to be attached, hoisted and lowered to the SS deck plate while the keel is in its raised position.

The carbon mast includes provisions for three internal halyards (mainsail, jib & spinnaker) including cleating at the mast base. The main halyard terminates on the black horn cleat to port while the jib and spinnaker halyards lead to the Harken pivot blocks on the mast with spinnaker to starboard. An aluminum mast track is provided with two gate options (interchangeable). One option is for use with a bolt-rope style luff on the mainsail, the other is for use with mainsail sliders to keep the mainsail captive to the mast. Mast is also equipped with two strap eyes at the mast base, a vang lug and a boom gooseneck fitting.

The J/70 boom is equipped with an adjustable outhaul system led to a jam cleat and lead block on inboard end of boom, soft attachments for both the vang block and the mainsheet strop, Antal sheaves outboard for both outhaul and a clew reef, and finally a jam cleat and cheek block for the inboard end of an optional owner supplied clew reef line.

***IMPORTANT! CARE SHOULD BE TAKEN WHEN HOISTING AND LOWERING THE MAST TO FIRST REMOVE THE VANG LUG AND TO PROPERLY SUPPORT AND PAD THE MAST AT ALL TIMES IN ORDER NOT TO DAMAGE THE MAST TRACK, THE MOLDED DECK RISER AROUND THE COMPANIONWAY AND THE SS DECK PLATE.***

## Jib halyard fine tune adjustment

Unique to the J/70 is a jib halyard fine tune. This is a 4:1 floating purchase system on the port side of the mast that attaches to a spliced loop on the jib halyard that appears from the jib halyard exit on the mast once the jib is hoisted. The beauty of this system is that the jib halyard tension can be controlled right from the cockpit without the need for winches.

## Jib Furling System

The J/70 is equipped with the Harken small boat below-deck jib furler system. The system includes a hoist-able swivel that rides on the headstay, a top swivel and a deck-mounted swivel with below deck drum. Because the headstay itself (and thus the sail) is what swivels, it is sensitive to halyard tension and initial set-up. The furler is not designed for a partially reefed position so you should plan to either sail with the jib entirely rolled up or fully unrolled. Please read the complete guide provided by Harken to best understand the system and how to get the best results from it. For initial set up the furling line should be rolled onto the drum in a counter clockwise direction.

## Cockpit Safety Lines

The safety lines surrounding the J/70 cockpit are built by Marlow Ropes and made from 5mm Dyneema or otherwise known as UHMwPE. These "soft lifelines" are attached by luggage tagging the forward end

to the foredeck mounted padeyes and running through the stanchions aft where the Hi-load thimble is slipped into the end splice and lashed to the stern rail. The average breaking strength of D-12 SK78 used by Marlow for these safety lines is 2400 kg (5,290 lbs). A stern cockpit safety line is also provided with a small SS pelican hook for easy removal.

A few facts from the Marlow website regarding Dyneema:

- High Strength: On a weight for weight basis, Dyneema® is 15 times stronger than steel wire
- Light Weight: Strength for strength, Dyneema® is 8 times lighter than steel wire. Dyneema® also has a Specific Gravity of 0.97 which means it floats in water
- Water resistant: Dyneema® is hydrophobic and does not absorb water, meaning it remains light when working in wet conditions and is therefore also more durable
- Chemical resistance: Dyneema® is chemically inert, and performs well in dry, wet, salty and humid conditions, as well as other situations where chemicals are present.
- UV Resistant: Dyneema® has very good resistance to photo degradation, maintaining its performance when exposed to UV light

## Cockpit Safety Line Installation

- Remove the thimble from the eye splice on the long section. This is the aft end of the safety line.
- Thread the forward end eye splice through the padeye on the foredeck, and then thread the aft end eye splice through the forward one. Pull tight to “luggage tag” the safety line to the padeye.
- Thread the aft end eye splice through both stanchions and the lifeline pad(s) and reinsert the thimble – it will be somewhat loose.
- Take the lashing (the shorter, thinner piece with the eye splice in one end) and “luggage tag” it through the bale on the stern pushpit.
- Pass the lashing through the thimble in the aft end of the safety line and then back through the bale on the pushpit, pulling aft on the safety line to maintain tension.
- Make 3 or 4 passes, keeping the direction constant and maintaining tension.
- After exiting the pushpit bale on the last pass, make several half-hitches onto the bundle of lashing passes between the pushpit and the thimble.
- Tape the last couple of inches of tail to the bundle for a finished appearance (black electrical tape works very well).

Your safety lines and lashings should be checked for wear as part of a regular boat maintenance program. Potential chafe areas are stanchion pass-throughs and the aft section where the spinnaker sheet transitions from “inside” to “outside”. Also remember to rinse the safety lines whenever you rinse your boat and deck hardware, as sharp salt crystals deposited when sea water dries can be a source of chafe. According to Marlow Ropes, properly installed and cared for J/70 safety lines should easily offer 5 or more seasons of service.

## Running Rigging

J/70 includes a refined package of running rigging developed with Marlow Ropes to match the requirements of the J/70. The package includes each line in labeled bags with an inventory list included in the sealed Marlow box. This box is not opened until the boat is delivered to the dealer or customer. A complete inventory of this rigging is also listed within this manual, and available directly from Marlow. To properly rig each system please refer to the rigging diagrams printed in this manual.

## Rigging Your J/70

### Tools & Supplies

- Phillips head screwdriver
- Flat head screwdriver
- Adjustable wrench
- Portable Drill with  $\frac{3}{4}$ " dia. long socket
- Needle nose pliers
- Knife/scissors
- Black rigging tape
- White rigging tape

### Before Stepping the Mast

- Set mast up on two padded saw horses
- Install spreaders to spreader brackets... (refer to the included Southern Spars J70 Guide).
- Install an optional Windex to top of mast.
- Attach backstay to masthead crane.
- Assemble top of headstay by attaching loose Harken swivel to T-bar fitting and top of wire headstay.
- Measure the headstay length. We recommend a starting length of 8432mm from the bearing point of the Gibb fitting at the top of the assembled headstay (with upper swivel in place) to the pin centerline of the bottom turnbuckle. Consult your sailmaker for a more specific recommendation.
- Install headstay.
- Install all side shrouds.
- Be sure that the five black rubber plugs are inserted into the shroud-to-mast terminals so that the shrouds and headstay don't pop out or become mis-aligned during stepping operations.
- Install upper shrouds into spreader end retaining fittings.
- Tape spreader ends and all exposed pins.
- Add contrasting tape calibration marks on spreaders (per sailmaker recommendation) for visual gauge of jib leech location.
- Install three halyards using the pre-fed messenger lines.
- Tie stopper knots in the lower ends of all halyard tails.
- Remove vang lug bolt and lug and store in safe place.

### Stepping the Rig

***DANGER! CONTACT WITH OVERHEAD ELECTRICAL WIRES COULD BE FATAL!  
PLEASE USE EXTREME CAUTION WHILE STEPPING THE RIG, LAUNCHING AND  
SAILING! THE CARBON FIBER MAST WILL CONDUCT ELECTRICITY***

- Align the mast such that the mast step is in proximity to the SS fitting on deck being careful to support and pad the mast at aft end of boat.



- Tie together a suitable 20-30' extension line to the top of either the main halyard or spinnaker halyard.
- Pin all side shrouds onto the side chainplates being sure that turnbuckles are well loosened.
- Double check that headstay is installed and fittings aligned at the top and turnbuckle is ready to be pinned to furler tack fitting.
- Remove the hinge pin from the mast step and arrange mast step over the SS loop of the deck fitting.
- This will require someone to lift the mast at the aft end of the boat, and/or can be achieved by fashioning a support.
- **IMPORTANT NOTE: IT IS ALWAYS NECESSARY TO SUPPORT THE AFT END OF THE MAST AT LEAST 20" ABOVE a 2 x 4 support bridging the stern rails in order not to overstress the SS loop on the mast deck plate when lowering the mast.**
- Lift the mast while a helper pulls the extended spinnaker or main halyard from the front of the boat.
- Once mast is up, pin headstay properly before releasing any tension from lifting halyard.
- Connect backstay with two shackles after running Harken backstay blocks (see backstay diagram).
- Take up turnbuckles evenly on port and starboard side shrouds until hand tight.
- Install boom vang lug

### After Stepping the Rig

- Rig a piece of elastic chord to the port side lower shroud, approx. 1-2' below the spreader, then pass it in front of the mast and secure to the other lower shroud. This helps "prevent" the spinnaker from catching (during the hoist) in the triangle created by the mast and the lower shroud (at the spreader).
- Set-up mast base blocks
- Install boom
- Begin installation of running rigging systems per the J/70 rigging diagrams on the following pages



## J/70 Mainsheet & Traveler

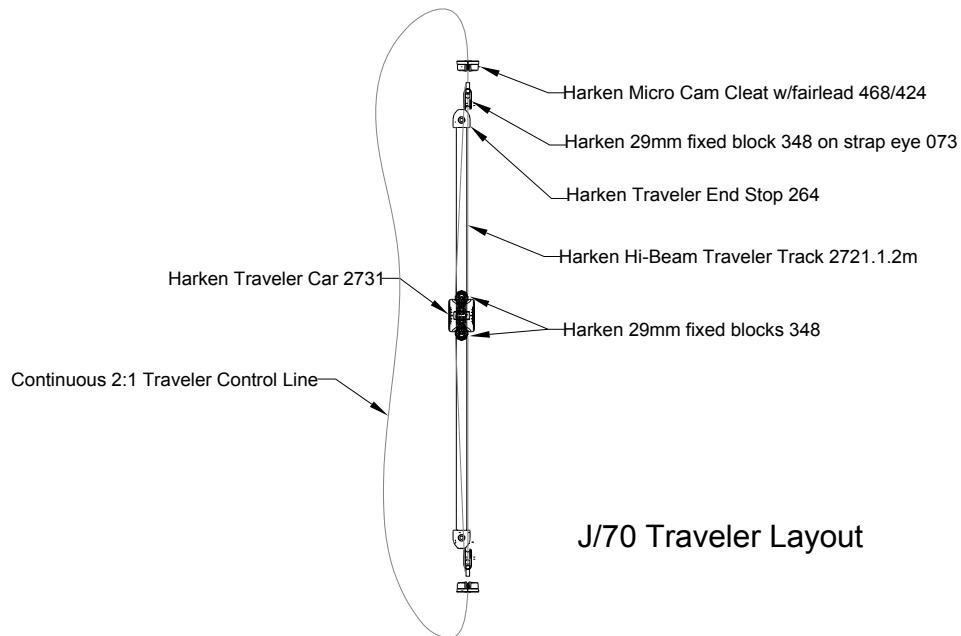
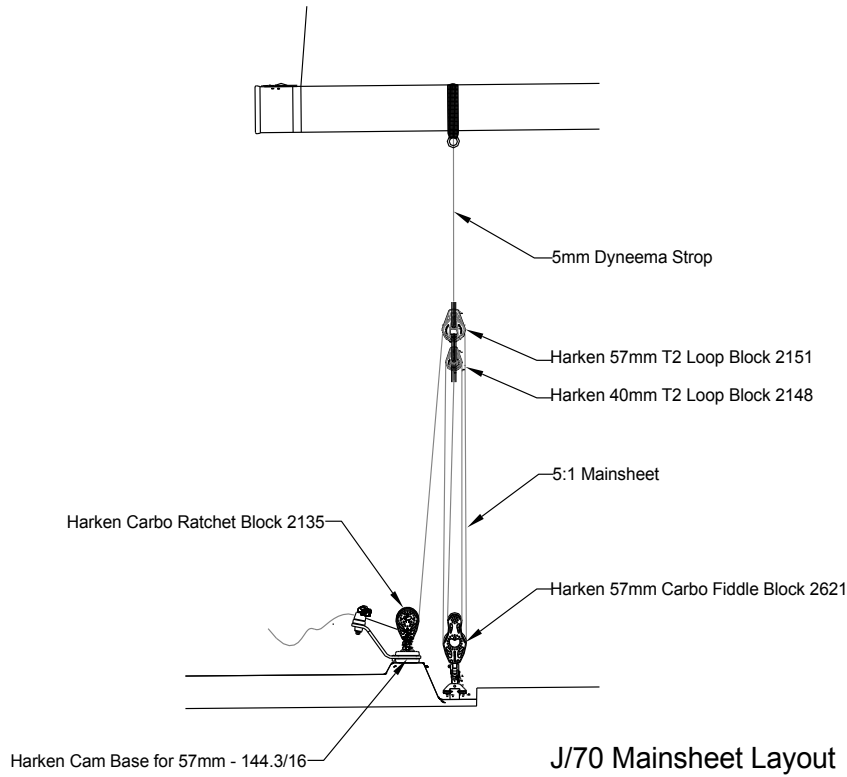

### J/70 Backstay System

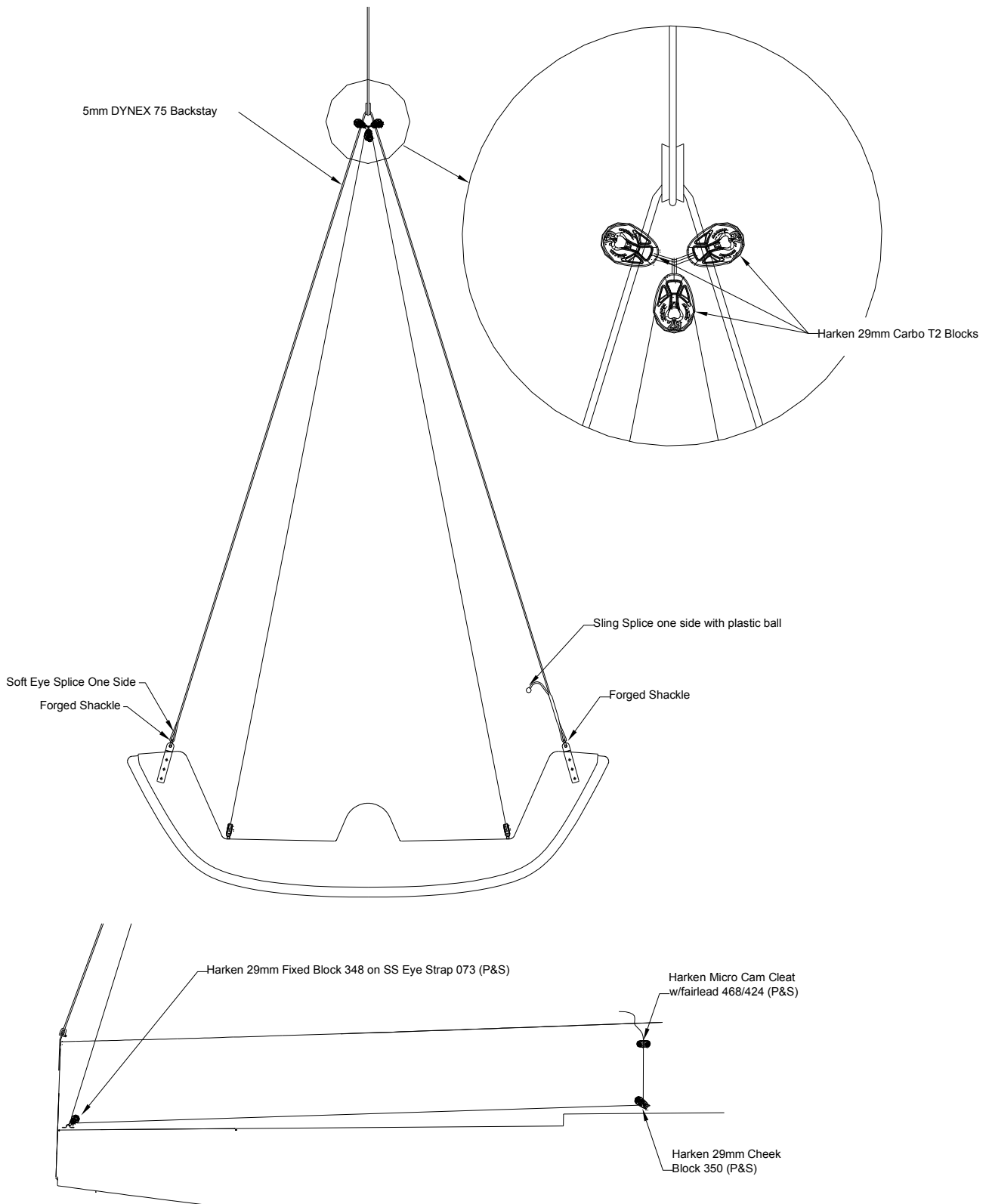

## J/70 Boom Vang & Cunningham

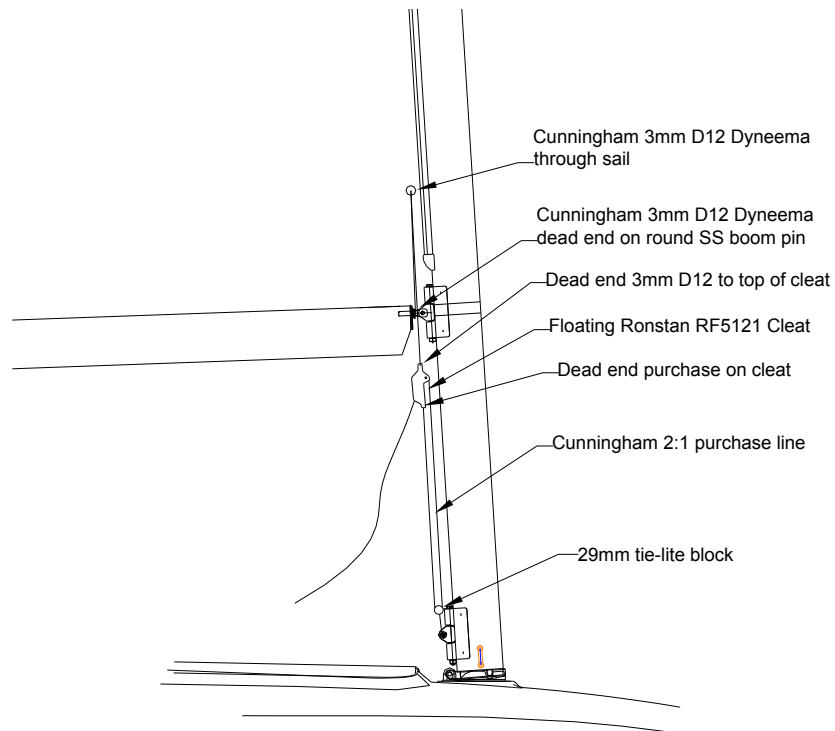
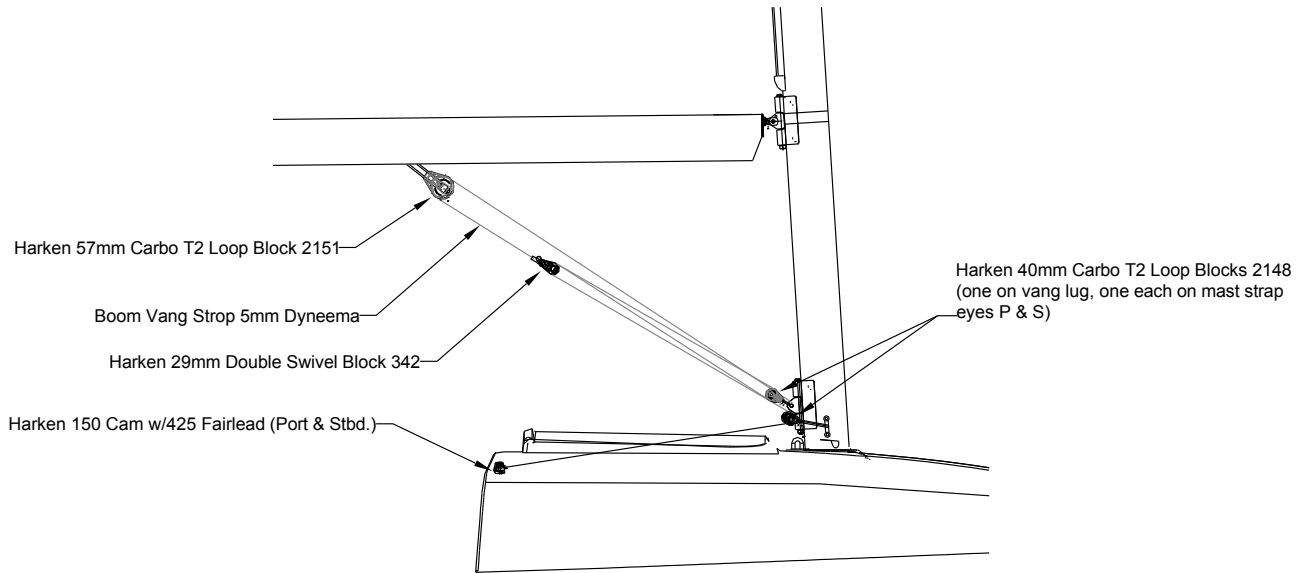

## J/70 Halyard & Mast Base

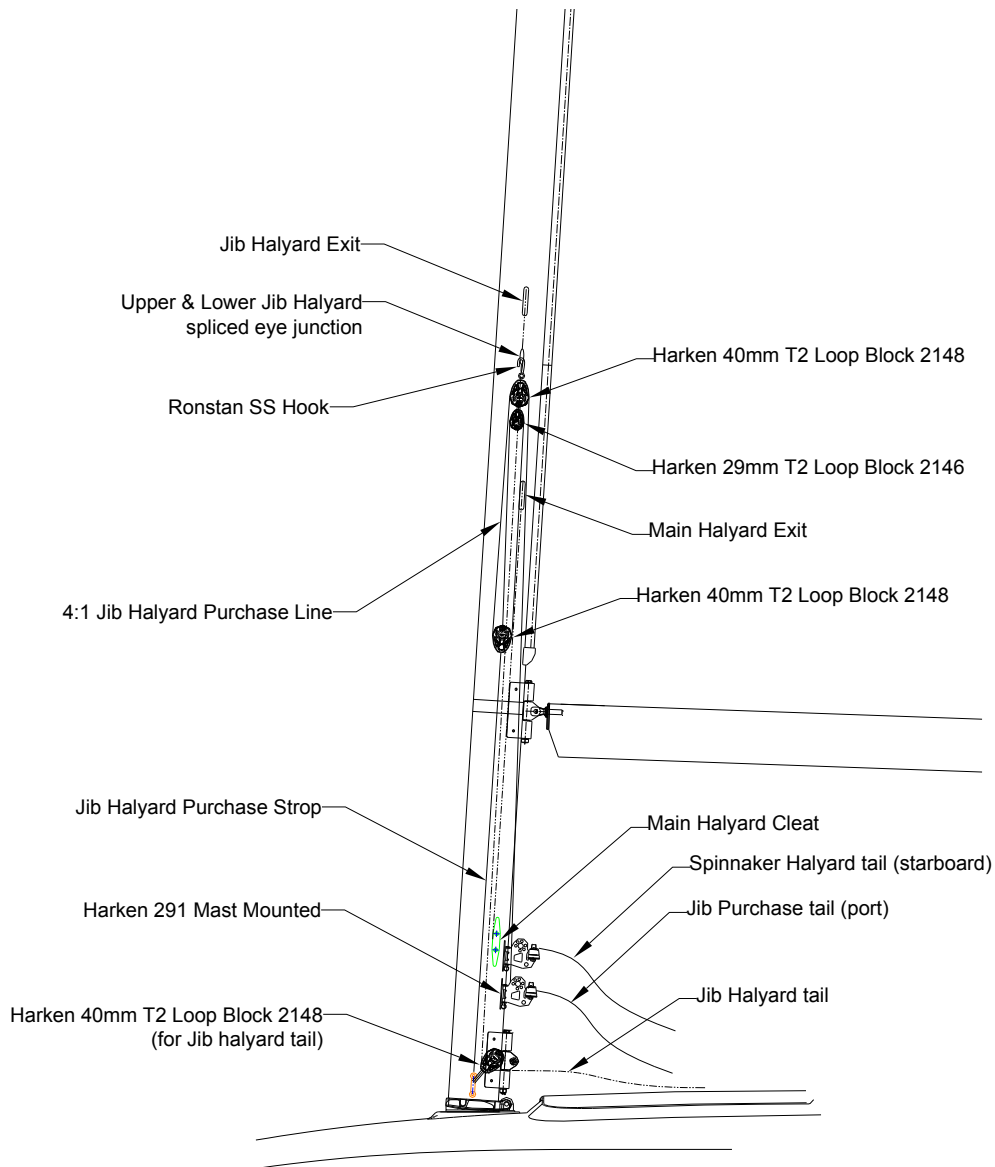

## J/70 Headstay Layout

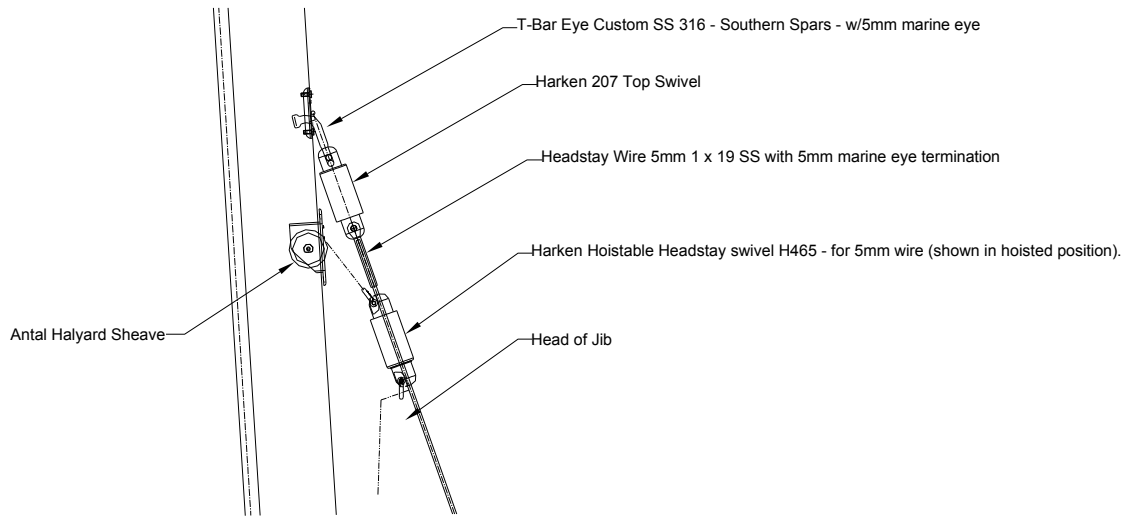

Top of Headstay - Detail

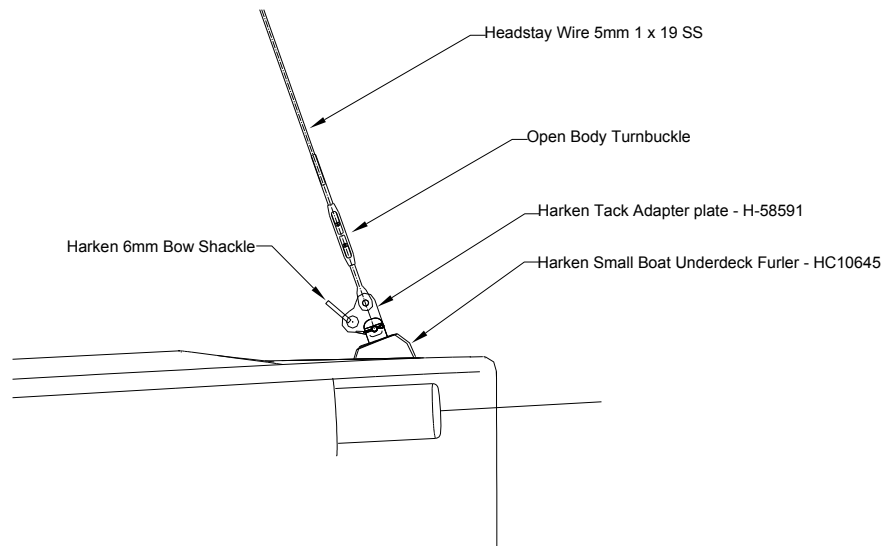

Bottom of Headstay - Detail

### J/70 Jib Sheet Layout - 2:1 Purchase

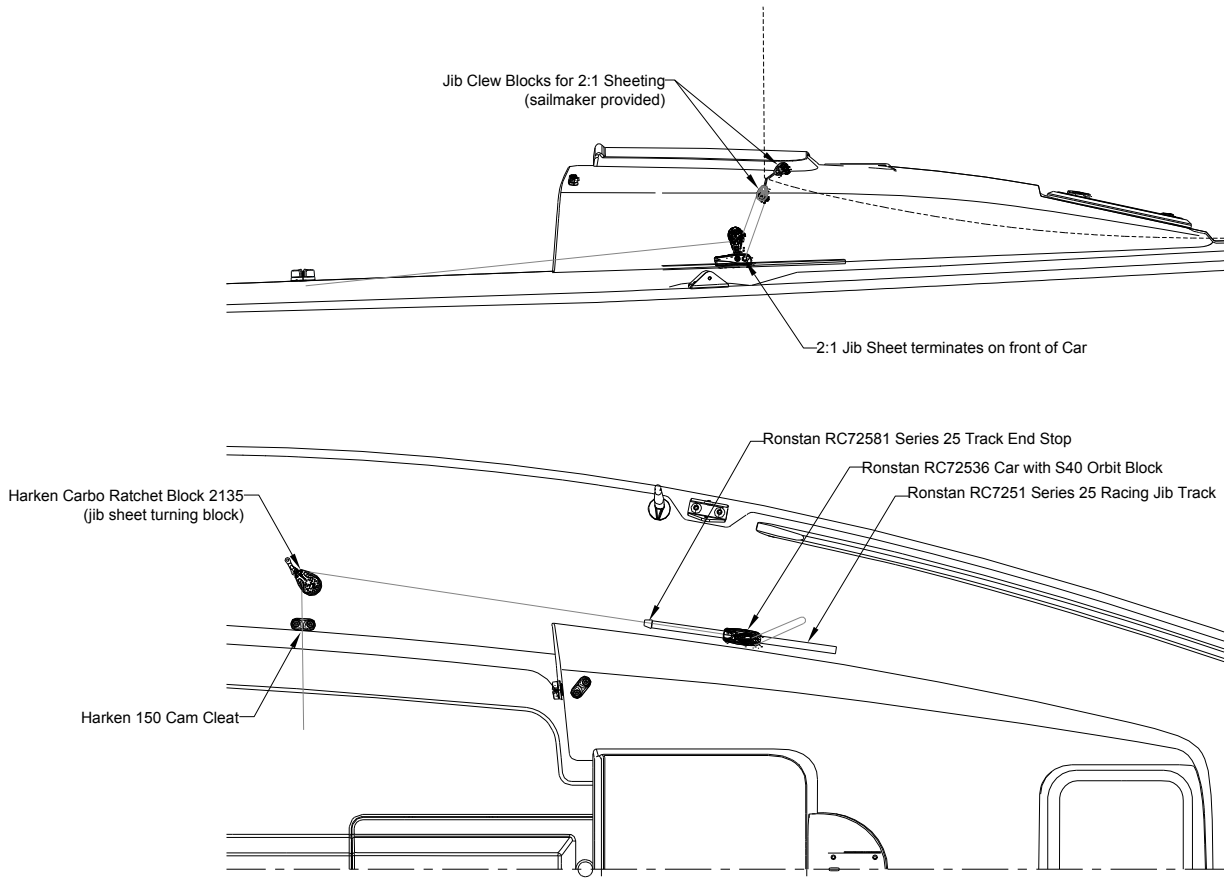

### J/70 Boom Layout

Note: Reef line is not a standard item included with the J/70, but the boom reef hardware shown is provided standard should an owner wish to add reef capability.

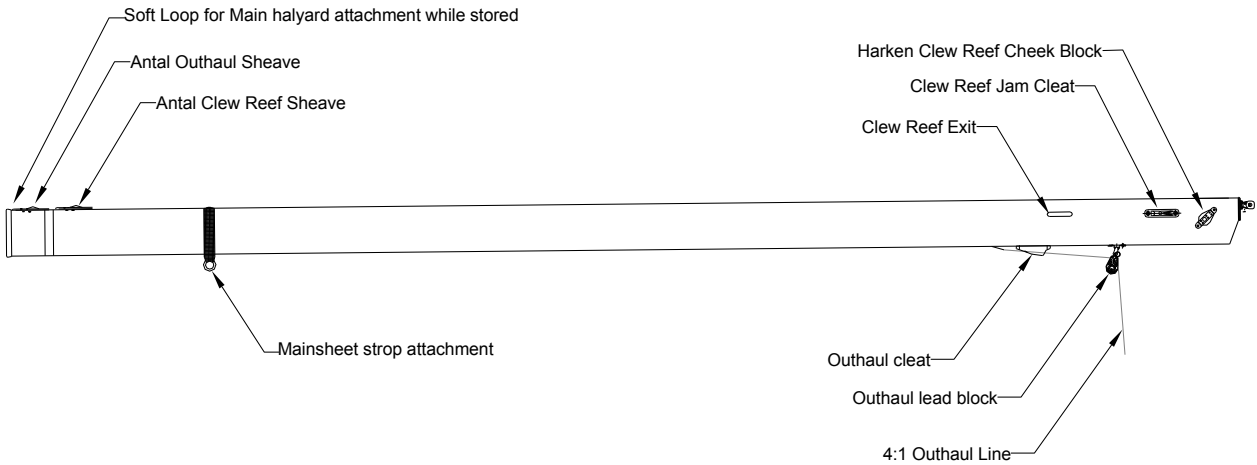

### J/70 Deck Layout

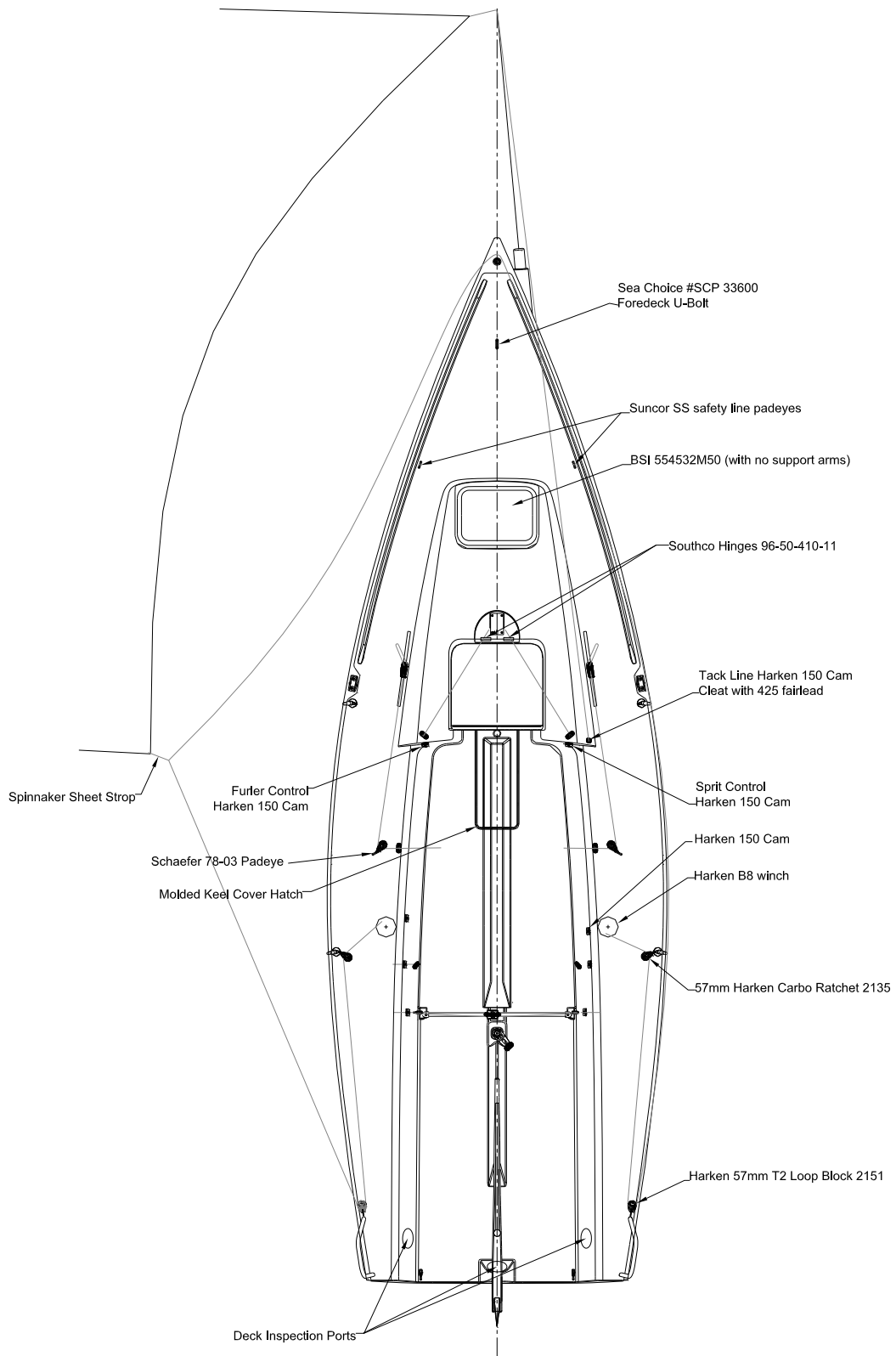

## J/70 Bow Sprit & Furler Controls

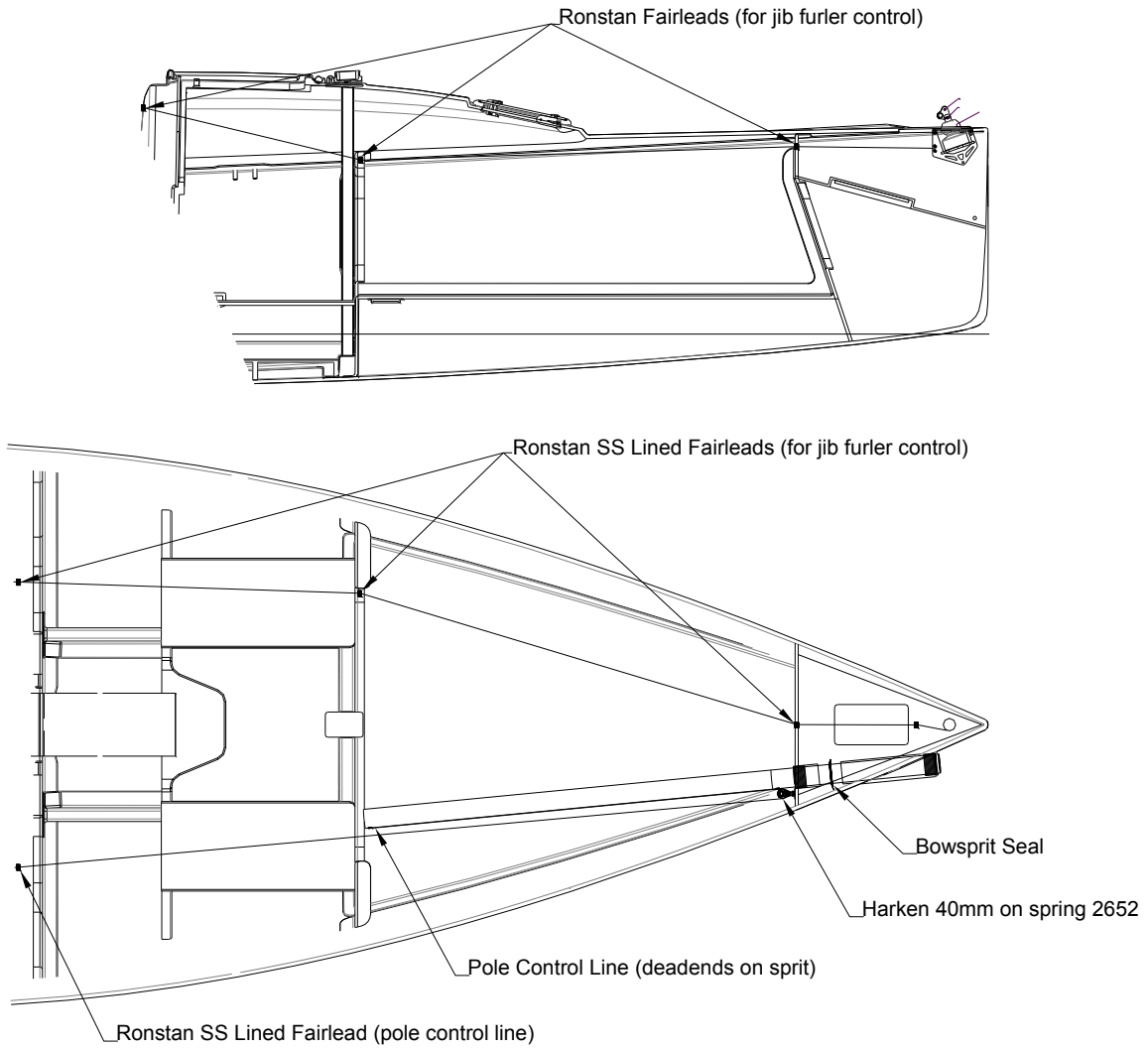



**J/70 Bow Drainage Locker & Access:**

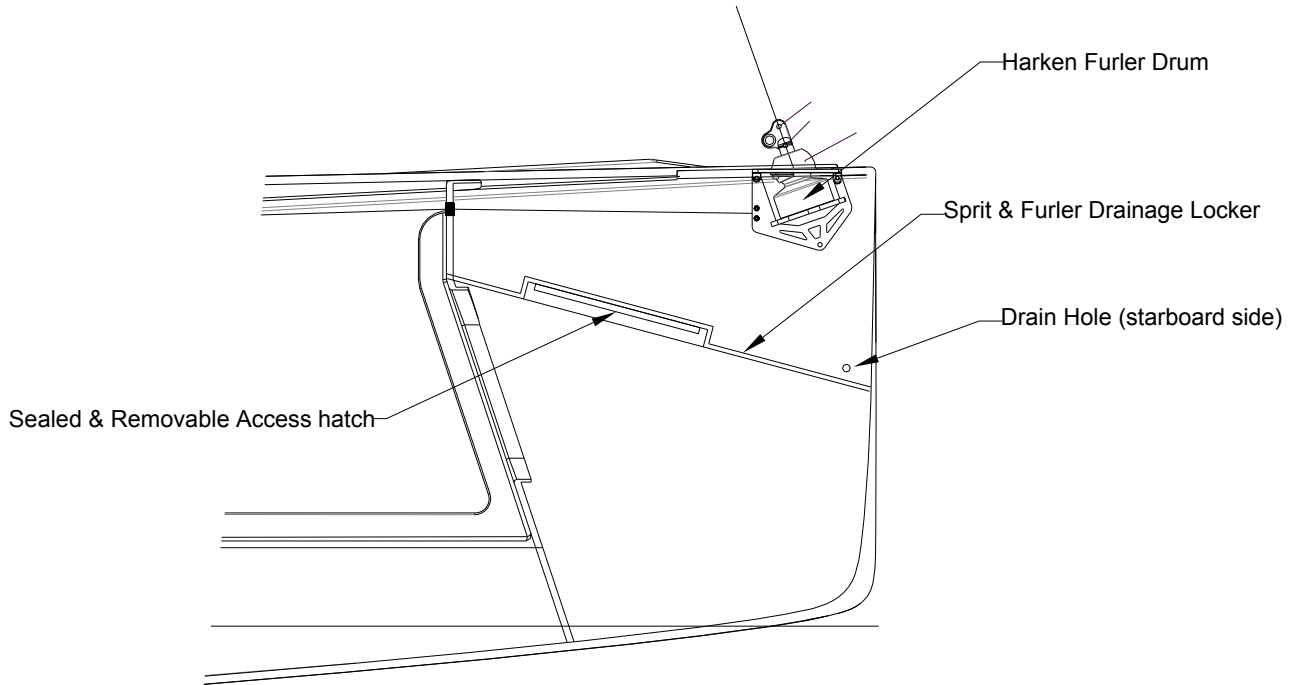

### J/70 Custom Keel Crane

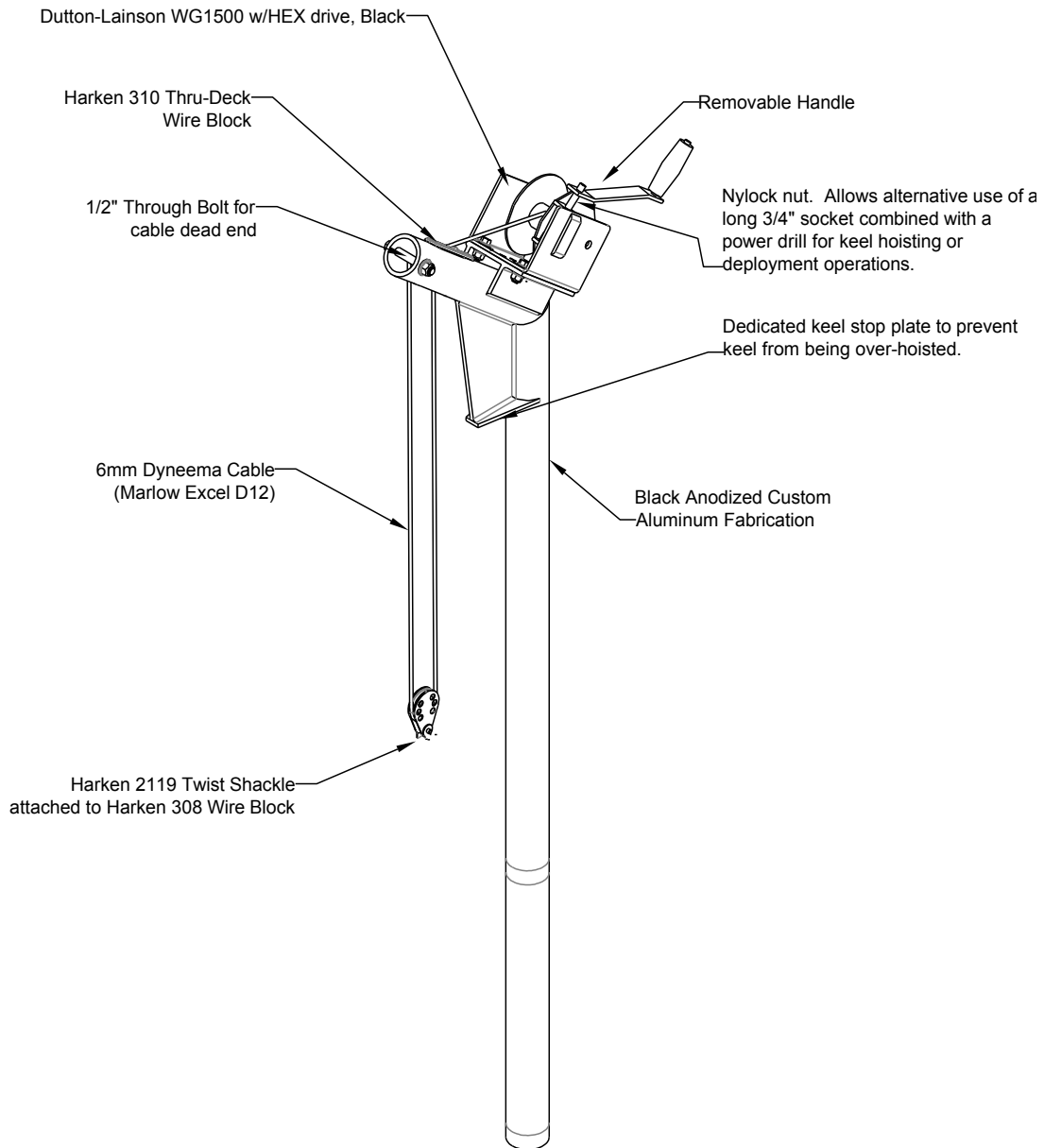

## Launching & Hauling Your J/70

***NEVER USE THE KEEL LIFTING-EYE TO ATTEMPT TO LIFT THE ENTIRE VESSEL!***

The keel lifting-eye is specifically designed to be used ONLY with the standard aluminum J/70 keel crane and to support the weight of the keel. Significant damage may occur to the keel, kelp cutter and bottom of the boat should this warning be ignored. The vessel must only be lifted with the (2) installed Harken padeyes located on either side of the keel under the cockpit keel cover.

### Pre-launch check-list

- Caution!! Beware of dangerous overhead power lines.
- Completely read and review the Getting to Know Your J/70 section of this manual
- Owner should prepare his boat with safety gear, tools, spares and PFDs for all crew members.
- Prepare & rig items per the J/70 rigging diagrams.
- Prepare & check that rudder and rudder hardware are ready for post launch installation.
- Attach docklines and fenders.
- Securely install outboard engine on the transom bracket.
- Check for adequate fuel and/or battery charge for outboard.
- Remove all trailer tie down straps except for bow winch strap.
- Rig the keel crane and lift keel off the keel support tray.
- Extend optional trailer extension (if necessary).

### Launching from Ramp

- Caution!! Beware of dangerous overhead power lines.
- Slowly back boat into water, start engine and back boat off of the trailer.
- Proceed to nearest dock to install rudder & complete any unfinished rigging tasks.

***DO NOT ATTEMPT TO SAIL OR OPERATE THE J/70 WITH THE KEEL IN LIFTED POSITION OR ATTEMPT LIFT OPERATIONS OF THE KEEL IN OPEN WATER!***

The J/70 is designed with a lifting keel system in order to facilitate short term launching operations at a wide variety of boat ramps and lift locations. With the keel retracted the J/70 will lose stability which will increase the risk of roll-over and capsize. At no time shall the J/70 be operated under sail or in open water with keel in raised position. In addition, extreme caution is required during all keel lifting operations. Use the system ONLY when in close proximity to the launching dock and/or launch facility and with a minimum of crew on board.

### Hauling from Ramp

- Caution!! Beware of dangerous overhead power lines.
- Attach docklines and fenders.
- Unrig deck systems and spars as needed.

- Rig the keel crane and lift keel fully up to keel stop.
- Securely install outboard engine on the transom bracket.
- Remove rudder pins and rudder and safely secure below.
- Prepare trailer with side guides (if so equipped).
- Slowly back trailer into water and align with boat.
- Start outboard engine and carefully maneuver boat slowly onto trailer.

Note: It is preferable to float the boat as far to the bow stop as possible in order to avoid having to winch the boat on the trailer bunks. This will ability will vary depending on the ramp angle & depth. In some cases a trailer extension may be needed.

- Attach bow winch strap to foredeck U-Bolt and if necessary winch the bow to the bow stop.
- Slowly pull the boat/trailer safely onto land.
- Lower keel onto keel tray.
- Properly secure boat and keel to trailer.

### Hauling by Yacht Club or Boatyard Single Point Lift

The J/70 is equipped with two substantial padeyes installed on either side of the keel below the keel cover. Both padeyes are designed for use, along with a secured lifting strap, for hauling and/or launching operations with yacht club or boatyard single point lifting cranes. Use of a lifting strap should always include support with side stays to brace the boat from tipping from side to side and fore-aft stays to insure level trim. Do not use the keel lifting eye on top of the keel with any crane except for the supplied J/70 keel crane!

- Caution!! Beware of dangerous overhead power lines.

Many boatyards and yacht clubs allow boats to be stored on trailers with rigs up. It is very important to survey the parking lot BEFORE moving the boat to be sure there are no overhead power lines.

***CAUTION: USE OF A YACHT CLUB SINGLE-POINT HOIST OR OTHER NON-STANDARD CRANE TO RAISE THE J/70 KEEL WITH THE KEEL LIFTING EYE MAY CAUSE DAMAGE TO BOTH THE KEEL AND THE HULL AT THE KEEL TRUNK.***

***J/70 keel lifting eye should only be used with the standard black anodized aluminum J/70 keel crane which is designed with a stop to prevent over-hoisting. Do not combine the boat lift padeyes with the keel lifting eye in any way during hoist operations.***

## Tuning the Rig

Your sailmaker will have specific shroud tensions recommended for different conditions. The following is a general tuning guideline that will work well for most sails and conditions. Before tuning, be sure the headstay turnbuckle is pinned to the recommended length and the shrouds are connected.

Center the mast: Establish reference points on the toe-rail abeam of the mast, by measuring aft from the bow equidistant to both rails. Then hoist a metal tape measure up the main halyard. Measure from rail to rail and adjust the upper shrouds hand-tight until the top of the mast is centered. The lowers should be slack.

Tighten the uppers two turns per side until you reach a shroud tension of approx. 800 lb. as measured by a LOOS gauge. Then hand-tighten the lowers so that the mast is straight side to side while sitting up the mast track.

Once the mast is straight, tighten the lowers two turns per side up to 700 lb.

Tighten the backstay lashing/adjustment so that with the backstay line released, the backstay bridle rests approximately 12-14 inches below the intersection with the upper backstay.

This shroud setting is a good all-around starting point. In sea-trialing the J/70 with several sailmakers, we arrived at the following general "grid" using a LOOS PT-2 tension gauge:

Loos Gauge Settings:

| Wind Speed (kts) | Upper Shrouds | Lower Shrouds |
|------------------|---------------|---------------|
| 0-6              | 18            | 12            |
| 6-10             | 20            | 18            |
| 10-14            | 25            | 23            |
| 14-17            | 28            | 26            |
| 18+              | 30            | 30            |

New wire rigging tends to stretch a little. Be prepared to go through this same tuning procedure after your first day of breezy sailing and thereafter to check it periodically.

## Sail Handling Tips

### Sheeting the Main

The mainsheet is a simple 5:1 system that cleats on a swivel base in the center of the cockpit. The 2:1 traveler allows a large degree of flexibility to power up or depower the mainsail. In general it is good to depower with a vang sheet technique by attempting to twist off the top of the mainsail and depower with the backstay, while flattening the sail with the outhaul and Cunningham.

### Sheeting the Jib

For most day sailing, as well as racing in light to moderate winds, you can trim the 2:1 jib sheet directly from the ratchet turning block and then to its local Harken cam cleat. You also have the option to lead the sheet aft to the leeward winch and this is quite handy when single-handing. In windy conditions, you have a third option of trimming the jib sheet across the cockpit to the windward winch (cross sheeting).

This is a very helpful racing technique in big wind and wave conditions when you want both the weight on the rail AND the ability to constantly adjust the jib sheet.

## Spinnaker Handling

The J/70 spinnaker can be deployed out of either the foredeck hatch or the main companionway. The companionway hatch is more readily accessible from the cockpit and is our recommended launch spot so that everyone can remain in the cockpit during hoisting and retrieving. While it is possible to stand in the companionway and reach forward to the foredeck hatch, retrieving the spinnaker through the foredeck hatch (not considering any special retrieval system) becomes a two-person operation.

Before setting the spinnaker, be sure to rig a lower shroud preventer (elastic chord from lower shroud to lower shroud 1-2' below the spreader) and tape up anything that can potentially rip the spinnaker. This includes the boom vang/boom intersect, the shroud bases and any visible ring dings or pins. You might consider adding a spinnaker bag just inside the companionway opening, to help prevent the spinnaker from tangling with loose gear below.

## Hooking up the Spinnaker

With the J/70, we normally launch the spinnaker directly out of the main companionway, forward of the spreader and behind and on top of the jib sheet – so that it passes out between the lower shroud and the mast. While it is possible to hoist by going outboard and around behind the shrouds (J/22, J/80 style) it's a lot of extra distance to travel and one risks dragging the tack/foot of the spinnaker in the water.

Always remember to tape the halyard shackle after attaching. It can otherwise catch on the rigging while being hoisted and potentially open at an inopportune time. When hooking up the spinnaker for the first time, start by attaching the spinnaker sheet strop to the clew of the sail. Assuming that you want to set the spinnaker from the port side, hook the sheet strop up to sail on the port side in front of the spreader with the lazy sheet (starboard) running around the headstay and back to starboard. Then take the tack line from the bowsprit, run it aft to port (to port side of the headstay), and connect to the spinnaker tack, making sure the tack line stays on top of the lazy spinnaker sheet. You'll see the benefit of this later when the spinnaker is flying. With the tack line always rigged on top of the lazy sheet, the spinnaker is automatically rigged for "inside" jibing. This is when the clew of the spinnaker (during a jibe) passes in front of the headstay but aft of the spinnaker luff. An "outside jibe" (when the spinnaker clew goes all the way in front of the spinnaker luff) is only effective in high wind (20+ knot) conditions.

## Spare Parts

It's always prudent to carry spares. The following is a recommended list of items to keep on board:

- Clevis pins for shrouds
- Spare shackles for the roller furler
- Assorted shackles
- Spare Tiller extension
- Extra spinnaker sheet (this can then be used as a spare for anything)
- One extra jib block assembly
- Spare blocks (29mm, 40mm, and 55mm block)
- Dyneema lashing (20-25' of 1/16")
- Rigging tape
- Small tackle box to keep all the small parts above.

## Appendix A: Best Practices - Boat Inspection

J Boats has compiled, with the help of several industry experts, the following “best practices” inspection, maintenance and use guide for J/Boat owners. We urge each owner to read carefully the recommendations, to proactively and periodically inspect all critical components of your boat, and to contact anyone in the J/Boats network of dealers, builders and class associations if you need any assistance.

### INSPECTION OVERVIEW

Considering the typical high-frequency use seen by many J/Boats, at a minimum, we recommend that owners have their boats inspected on an annual basis and that a professional survey be done every five years. An inspection should include a detailed review of the high-load areas, such as the rudder and keel attachments, rigging terminals, structural bulkheads, keel floors, mast step, mast partners, steering systems, mast and boom fittings, lifelines, etc. Inspection should also include identifying any possible leaks, including thru-hull fittings, as well as identifying worn rigging and hardware. Additional inspections/surveys should be performed immediately after any instances of grounding, collision, and/or extreme weather sailing.

According to Carter Gowrie of the Gowrie Group, most insurance companies mandate a professional survey for boats at 10 years. A survey may indicate a structural or safety issue that an owner needs to address in order to continue insurance coverage. For boats that haven't changed hands (which usually triggers a pre-sale survey), it's otherwise left entirely to the owner to determine when a survey should occur.

### KEEL/ KEEL FLOORS

Overview - One of the most critical areas of a modern, fin-keeled composite boat is the keel and keel floor area. This is an area that absorbs incredible loads and enormous stress.

#### Use Considerations:

- 1) **Groundings** - after any grounding or collision with any underwater object, soft or hard, be sure to carefully inspect the keel, sump area and keel floors for any signs of cracking or weakness. This is best handled by a qualified marine surveyor. Even a seemingly minor grounding can weaken the overall structure, particularly if left un-repaired for any length of time and/or if the boat continues to sail without repairing. There have been cases where a moderate grounding revealed no visible damage (due to the bottom of the boat absorbing the impact and then returning to shape), only later to reveal the presence of fractured glass on the inner hull laminate just aft of the keel. Have repairs done by a professional yard with a follow-up survey.
- 2) **Trailing/ hauling** - boats that are actively trailered can be subject to excessive stress and strain. In fact, years of trailering alone can subject a hull and keel to excessively sharp vertical accelerations that can cause significant wear and tear on the composite structure.

Be particularly careful when strapping a boat down to the trailer. It's not uncommon at regatta venues to see boats quickly hauled and lowered onto their trailers, with little time to get the boat aligned and sitting properly on the supports, then strapped down hard onto the trailer with powerful ratcheting webbing straps and then driven off. In short, the hull is being pulled down hard and in a very short period of time is potentially subjected to excessive stresses and strains.

**If you have a bow-stop on the trailer, use shorter strap runs (running nearly vertical) over the boat rather than long diagonal straps through the bow and stern rails. This reduces the possibility of trailer flex contributing to any excess strain.**

Be sure to properly and carefully tie down the keel to the trailer as this component is independent of the boat and can otherwise bounce on the keel tray. Care should also be taken to properly protect the trailing edge of the keel inside the keel trunk to minimize movement inside this area while traveling.

- 3) **Docking & mooring** - care should be taken to avoid mooring or docking your boat in locations that can result in the keel being occasionally imbedded in mud/sand/silt when at low tide or low water. A combination of the keel bulb imbedded with any sort of wave action against the hull can cause undue stress to the hull and keel structure. The same is true for boats that use special dockside hoisting systems to hoist the hull out of the water, while the keel remains underwater and unsupported.

#### **Maintenance Considerations:**

- 1) Care should be taken to avoid having standing water in the bilge. Not only does standing water accelerate corrosion of fasteners and bolts over time, it will promote mildew and other unwelcome growth inside the boat. As the gelcoat/ paint ages in the bilge area, bilge water can eventually seep into the fiberglass laminate by way of pin holes in the gelcoat and weaken the fiberglass laminate structure. *The process of hydrolysis can be initiated in the fiberglass laminate anytime there is ingress through cracks in the paint/gelcoat in the bilge. The process of hydrolysis is persistent and invisible- it's water that chemically degrades the quality and strength of the laminate over time.* Bilges (all areas not just the centerline bilge) should be cleaned thoroughly once per year and then every five years recoated with fresh gelcoat or epoxy paint to ensure proper protection. In northern climates, water turns to ice in the winter. If moisture gets into the laminate and freezes, this can rapidly accelerate deterioration in the laminate. The New Hampshire Materials Testing Labs website ([www.nhml.com](http://www.nhml.com)) has an informative article on hydrolysis, see Newsletter of May 1, 2006.
- 2) In any cored hull, take special care to avoid having any fasteners penetrate the inner hull laminate. Water in the bilge area can easily weep through the fastener into the laminate and cause core damage. If you need to secure a fitting or wire tie to the hull, the best fastening method is to glue epoxy coated marine plywood blocks to the hull and then fasten into the ply.

#### **RIGGING**

- 1) **Standing rigging** - The general rule of thumb is that standing rigging (whether wire or rod) should be replaced every 10 years, unless excess strain due to hard ocean sailing shortens this life. Fatigue can be in any form- sailing in extreme wind conditions, unnecessary flogging of loose leeward shrouds, corrosive environment. Any signs of a broken wire strand(s) indicates immediate replacement is necessary. Otherwise keep a close look out for corrosion or cracking in the swage fittings and turnbuckle threads. In southern coastal areas, with the high salinity and year round warm weather, rigging must sometimes be replaced every 5 years. Fresh water sailed boats will generally have a longer rigging life, but are still subject to fatiguing after years of stress.



- 2) **Headstay** - The top of the headstay (wire or rod) should be checked to make sure it's not bent. The fasteners and the top of the headstay foil should also be routinely checked.
- 3) **Clevis pins** - More rigging and spar mishaps are caused by clevis pins backing out, than perhaps any other culprit. If the clevis pins are semi-permanent (only removed a few times per year), then use appropriate sized cotter pin and fully bend them back around the clevis pin. Then cover with clear sealant rather than tape so that they are visible.
- 4) **Running rigging** - suffers the greatest wear and tear (chafing primarily) and should be checked frequently for wear, particularly high load lines like main and jib halyards and jib sheets.

### SPARS

- 1) Spar life can vary, but a general rule is the mast should be replaced every 20 years. Frequently check your spar for problems. Spars break more often than not by a failure in the standing rigging, but there are some specific areas to keep an eye out for:
  - 2) **Deck area** - The SS mast step on deck section is usually subject to the most abuse over time as it will be subject to constant rig stepping operations. Be sure the SS loop is checked periodically for any sign of weakness.
  - 3) **Spreader tips** - these should be untaped and inspected annually. Use spreader chafe covers that won't collect water.
  - 4) **Rig tuning** - to provide not only the best performance but also a longer mast life, it's very important to properly "tune the mast." Tuning means adjusting the shroud tension so that the top of the mast is centered over the boat, and such that the mast is in column or straight as you site up the mast groove on the aft side. Proper tuning for all conditions usually means maintaining enough tension on the shrouds so that they do not go completely slack on the leeward side while sailing. Many successful one-design classes have tuning guides published and provided by sailmakers. Some of these may suggest very loose settings on the shrouds for better light air performance. Care should be taken by owners to avoid sailing in windy conditions with light air shroud settings. This may significantly shorten the life of the mast and lead to breakage.
  - 4) **Aluminum spars** - are subject to corrosion and fittings should be routinely inspected and replaced when necessary. Particular problem areas over time can be fasteners around boom vang, boom and mast ends, and gooseneck attachment brackets.
  - 5) **Booms** - often have a shorter life than masts, particularly on race boats that do a lot of windward-leeward buoy racing in breezy conditions. In some class boats it is common practice to pull the boom vang hard going upwind (vang-sheeting) and then release the boom vang several inches going downwind. However if one bears away without first releasing the boom vang (from its vang-sheeted position) then most booms will bend under this load. Repeated occurrences will shorten the life of the boom and could cause breakage.
  - 6) **Rig cutting tool** - Every sailboat should carry aboard a tool that is capable of cutting through standing rigging quickly. When a mast does break, the portion that is in the water can easily ram a hole and potentially sink a boat. You may not have time to unwrap the rigging tape and pull clevis pins at all the attachment points. The top of the line cutters are hydraulic, which can be

used on wire or rod rigging. For small one designs (ex...J22, J70, J24 & J80), a good hacksaw should be carried at a minimum.

## OTHER STRUCTURE

- 1) **Bulkhead tabbing** - the primary structural bulkheads of the boat are tabbed or glued both to the hull and to the deck. This tabbing/glue (or fiberglass tape) should be inspected annually and, especially, after any groundings or excessive exposure to "hard trailering". If there is any evidence of gelcoat cracking or actual tabbing or glue flanges visibly loose or beginning to peel, ensure that a marine surveyor inspects the boat and recommends adequate remedies to correct potential damage.
- 2) **Hull-to-deck joint** - all modern J/Boats are built with a "glued" PLEXUS (2-part glue) hull to deck joint. It is an ISO/ABS approved method for hull-to-deck bonding. This joint should be inspected at least annually and, in particular, if any leaking is noticed inside the hull. Sometimes the best check is to use a "non-permanent dye" in water to squeeze into the hull/deck joint and look for "runs" inside the hull. If any leaking is observed, have the hull to deck joint surveyed and have the surveyor make recommendations for adequate remedies to correct potential damage.
- 3) **Chainplate fittings** - Both port and starboard chainplates and the bow and stern chainplates should be checked at least annually. Look for leaks where they intersect the deck.
- 4) **Bow sprit system** - the sprit system is a combination of a carbon tube, pulley system and an integral bulkhead/housing support. The system can easily be damaged, particularly when struck laterally or vertically at the end of the pole with any force (e.g. when rounding marks hitting sterns, hitting metal buoys, or burying the bow in steep seas under full force of the asymmetric spinnaker too many times). Regularly inspect the sprit for excessive wear where the sprit intersects the outer bearing at full extension.

## DECK HARDWARE

- 1) **Wire lifelines and lifeline fittings** - should be replaced at least every 10 years or at the first sign of corrosion or damage to the wire strands, swages or turnbuckles. Many older boats have white vinyl coated lifelines, which are no longer allowed by ORC Offshore regulations, as the vinyl can disguise ongoing corrosion or damage to the wire. These should be replaced using appropriate wire type and diameter immediately. Boats equipped with soft Dyneema or Spectra lifelines should be inspected more frequently for wear at all stanchions and fittings.
- 2) **Sealants** - used for deck hardware can last anywhere from 3 -10 years depending on the stress exerted on the hardware. If most of your hardware is still original, you should consider backing off the fasteners and rebedding with Sikaflex or other suitable marine sealant. Jib and genoa tracks are usually the first areas to start to leak over time. Stanchion set screws should be re-inspected and replaced when necessary.

## ADDITIONAL REMARKS

There are few industry guidelines regarding pro-active maintenance, inspection and periodic replacement of key components on aging composite boats. Many owners rely on reminders from their boatyards for upgrades or required maintenance. For trailerable one-designs, it's mostly up to the owner

unless a surveyor gets involved with a pre-sale survey, and even then, not all surveyors are versed in composites. There are critical areas on every boat that need to be vigilantly looked after and routinely inspected, and we strongly encourage all owners to start by inspecting their boats now to best ensure a long, productive life.

*FOOTNOTE: The contents of this article are thought to be accurate, but do not necessarily include all of the possible preventative maintenance suggestions that owners could follow to ensure long-term, safe operation of their boats. Boats incur wear and tear in unique ways. When in doubt please consult a professional for advice/instruction on maintaining, inspecting, repairing and/or operating your boat.*

## Appendix B: Marlow Running Rigging Specifications

| Item   | Qty | Dia (mm) | Material                   | Finish                          | Length (ft) |
|--|-----|----------|----------------------------|---------------------------------|-------------|
| Main Halyard                                       | 1   | 6        | Excel - Racing Black       | Splice on shackle/whip          | 71.9        |
| Main Halyard Shackle                               | 1   | -        | Wichard B536               | -                               | -           |
| Mainsheet  | 1   | 8        | MB12 - Black/Grey          | Pass eye/whip                   | 58.1        |
| Mainsheet Strop                                    | 1   | 5        | Excel D12 - S/Black        | 50mm soft eye/25mm soft eye     | 1.25        |
| Traveler   | 1   | 5        | Excel Pro - Black          | whip/whip                       | 15.25       |
| Vang   | 1   | 6        | 8-Plait Prestretch - Red   | whip/whip                       | 22.0        |
| Vang Strop   | 1   | 5        | Excel D12 - Black          | 25mm soft eye/25mm soft eye     | 3.75        |
| Cunningham 2:1                                     | 1   | 3        | Excel D12 - Black          | 50mm soft eye/50mm soft eye     | 3.0         |
| Cunningham Purchase                                | 1   | 6        | 8-Plait Prestretch - Black | whip/whip                       | 10.0        |
| Jib Halyard*                                       | 1   | 4        | Excel D12 - Black          | 25mm soft eye/25mm soft eye     | 21.0        |
| Jib Halyard Hoisting Tail*                         | 1   | 5        | Control Line - Tech/Red    | 50mm soft eye/whip              | 40.0        |
| * Jib halyard & hoisting tail are spliced together |     |          |                            |                                 |             |
| Jib Halyard Purchase                               | 1   | 6        | 8-Plait Prestretch - Lime  | whip/whip                       | 18.5        |
| Jib Halyard Purchase strop                         | 1   | 3        | Excel D12 - Black          | 25mm soft eye/25mm soft eye     | 3.0         |
| Jib Sheet 2:1                                      | 1   | 8        | MB12 - Red/Grey            | whip/whip                       | 47.9        |
| Spinnaker Halyard                                  | 1   | 6        | 8-Plait Prestretch - Blue  | Splice on shackle+ball/whip     | 75.1        |
| Spinnaker Halyard Shackle                          | 1   | -        | Ronstan RF6110             | -                               | -           |
| Spinnaker Sheet                                    | 1   | 7        | Excel Fusion - Blue        | whip/whip                       | 104.0       |
| Sprit Out  | 1   | 6        | MB 12 - Nat/Blue Fleck     | whip/whip                       | 22.3        |
| Tackline   | 1   | 6        | Excel Racing - Grey        | whip/whip                       | 32.2        |
| Backstay Control                                   | 1   | 6        | 8-Plait Prestretch - Lime  | whip/whip                       | 52.0        |
| Keel Crane Line                                    | 1   | 6        | Excel D12 - Black          | 50mm soft eye/whip              | 16.7        |
| Cockpit Safety Lines (side)                        | 2   | 5        | D12 SK78 - Black           | Brummel eye/Brummel eye         | 16.7        |
| Cockpit Safety Line (aft)                          | 1   | 5        | D12 SK78 - Black           | Splice on Gate hook/Brummel eye | 6.63        |
| Cockpit Safety Line Lashings                       | 2   | 3        | D12 SK78 Lashing line      | Brummel eye/cut                 | 1.50        |
| Rear Gate Hook                                     | 1   |          | CS Johnson                 | spliced to aft safety line      | -           |
| Allen Hi Load Thimbles                             | 2   |          | Allen Alloy                | One for each side safety line   | -           |

\*The above are original J/70 running rigging specifications from Marlow Ropes as of 5/14/12 and subject to change in quantity, diameter, material, finish and length at J/Boats discretion. For the most up to date rigging specifications please contact J/Boats, Inc.